

**Aviation Fabricators Inc.
805 North Fourth Street
Clinton, MO. 64735**

INSTRUCTIONS FOR CONTINUED AIRWORTHINESS

For

1 & 2 Place Divans

Document No.: AF-579

Revision "D"

Revision Date: 09/11/20

Applicable to:

Gulfstream models G-159, G-1159, G-1159A, G-1159B, G-IV

Modified by FAA STC SA2893SW

The information in the Instruction for Continued Airworthiness is FAA accepted material and complies with 14 CFR 25.1529, Instructions for Continued Airworthiness. It supersedes or adds to that provided in the Maintenance Manual for the Gulfstream G-159, G-1159, G-1159A, G-1159B, G-IV Model Aircraft, only where covered in the items contained herein. For limitations and procedures not contained in the Supplement, consult the applicable Gulfstream Maintenance Manual, or other approved airplane data.

REVISION PAGE

Document Title: Instructions for Continued Airworthiness

Prepared By: Todd Pogue

Updates to the ICA will be made by Aviation Fabricators Inc. Updates will be listed in the log of revisions and the effective pages will be listed below.

Log of Revisions				
REV. NO.	EFFECTED PAGE(S)	DESCRIPTION	DATE	APPROVED BY
Orig. Issue	All	Initial Release	01/03/14	GRL
A	14	*Changed restraint P/N in Section 8.0 Paragraph 3 from 3091-3-031-2396 to 3091-3-171-2396 per ECO # AF00512	09/15/14	JRL
B	6 & 7	*Removed references installation P/N's 62-0402K-1 & 62-0403K-1. All installations will now use the inertia reel attaching bracket.	03/15/17	JRL
C	14	*Changed restraint P/N in Section 8.0 Paragraph 3 from 3091-3-171-2396 to 3091-3-181-2396	08/13/19	JRL
D	All	*Updated Figure 1.0A with Detail A for the Hold Down Fittings, p 6 *Removed Section 11. Troubleshooting as not applicable *Updated Section 10 to latest format, p 17	09/11/20	JRL

TABLE OF CONTENTS

DESCRIPTION	PAGE
INSTRUCTIONS FOR CONTINUED AIRWORTHINESS	1
REVISION PAGE	2
TABLE OF CONTENTS	3
ABBREVIATIONS AND DEFINITIONS.....	4
1.0 INTRODUCTION.....	5
2.0 INSPECTION REQUIREMENTS AND OVERHAUL SCHEDULE.....	11
3.0 DIMENSION AND ACCESS:	13
4.0 LIFTING AND SHORING	13
5.0 LEVELING AND WEIGHING	13
6.0 TOWING AND TAXIING	13
7.0 PARKING AND MOORING.....	13
8.0 PLACARDS AND MARKINGS.....	14
9.0 SERVICE INFORMATION	15
10.0 AIRWORTHINESS LIMITATIONS	17

ABBREVIATIONS AND DEFINITIONS

Abbreviations	Definitions
FAA	Federal Aviation Administration
General Visual Inspection (GVI)	A visual examination of an interior or exterior area, installation or assembly to detect obvious damage, failure or irregularity. This level of inspection is made from within touching distance unless otherwise specified. A mirror may be necessary to enhance visual access to all exposed surfaces in the inspection area. This level of inspection is made under normally available lighting conditions such as daylight, hanger lighting, flashlight or droplight and may require removal or opening of access panels or doors. Stands, ladders or platforms may be required to gain proximity to the area being checked.
ICA	Instructions for Continued Airworthiness
STC	Supplemental Type Certificate

1.0 INTRODUCTION

The purpose of this Maintenance Manual Supplement and Instructions for Continued Airworthiness (ICA) is to provide the maintenance technician with the information necessary to ensure the continued airworthiness of the Aviation Fabricators 1 & 2 place divans, when installed onto existing seat track in the aircraft passenger cabin in accordance with Aviation Fabricators design data included on STC Data List AF-242 and per Supplement Type Certificate (STC) No. SA2893SW.

Modifications to an aircraft obligates the operator to include the maintenance information provided by this document into the operator's aircraft Maintenance Manual and operator's aircraft scheduled maintenance program. This document defines supplementary maintenance operations and frequencies recommended by Aviation Fabricators Inc., to ensure the aircraft's airworthiness.

The information contained herein addresses the requirements specified in 14 CFR 25.1529, Instructions for Continued Airworthiness and supplements the basic Airplane Maintenance Manual only in those areas listed as pertains to the installation of divan assemblies, as installed per the Aviation Fabricators STC Data List AF-242. For limitations and procedures not contained in this supplement, consult the basic Airplane Maintenance Manual.

DATA

All information to support the continued airworthiness of this modification is contained in:

STC SA2893SW.
STC Data List: AF-242.

Installation: Installation Instructions D-10739

Parts: P/N 62-0402, 1 Place Divan
P/N 62-0403, 2 Place Divan

The divan is a self-contained complete assembly that mounts to the existing cabin seat track, using standard fittings, in accordance with FAA approved floor plans.

Design Change Control

All data and changes to the parts and assemblies will be tracked per STC Data List AF-242 Rev K or later approved revision.

Applicable Aircraft

Gulfstream models G-159, G-1159, G-1159A, G-1159B, G-IV

1 & 2 Place Divans
2 Place Divan Shown
Top not shown for clarity

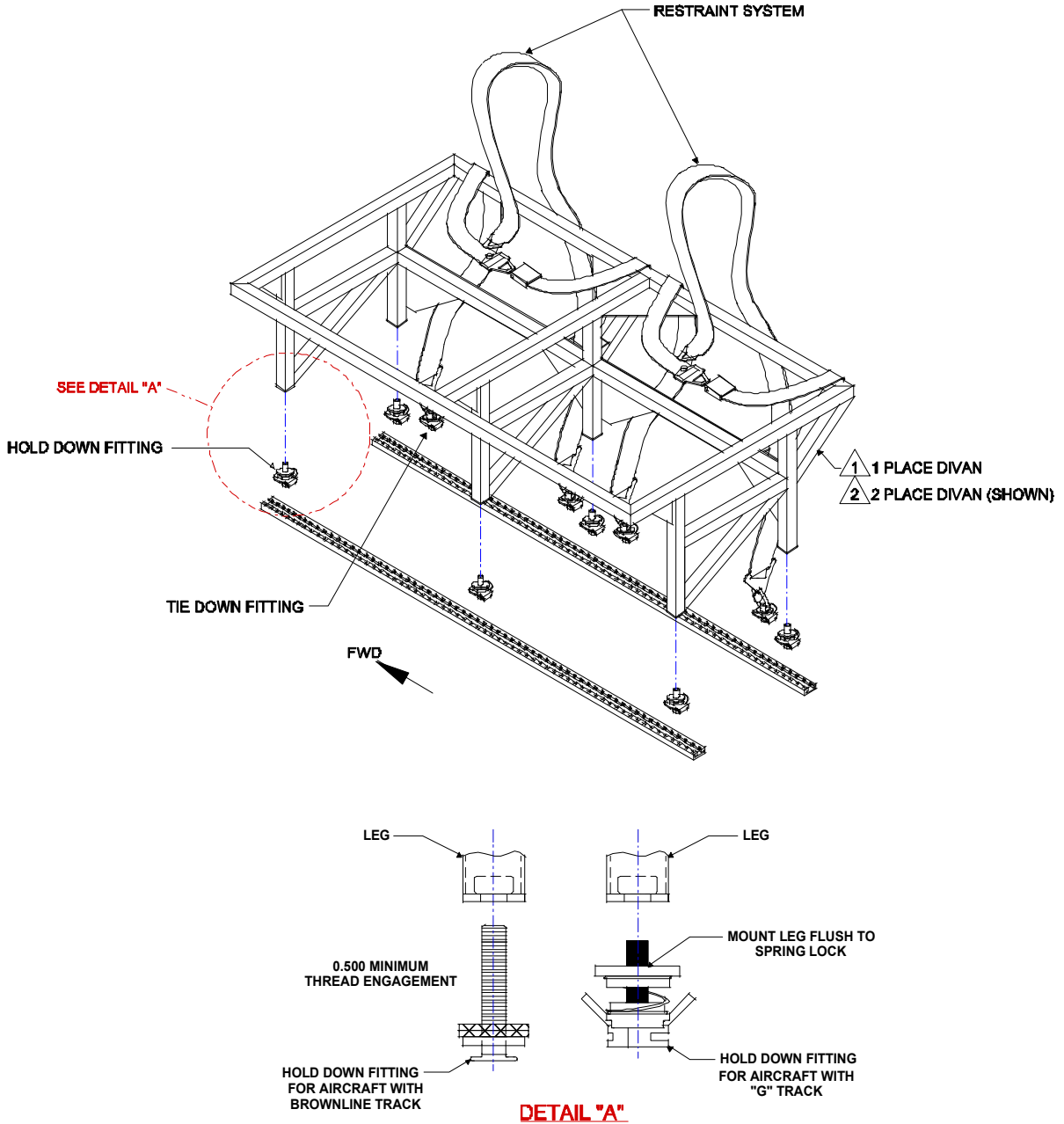

Figure 1.0A

Close-out Panel Assembly

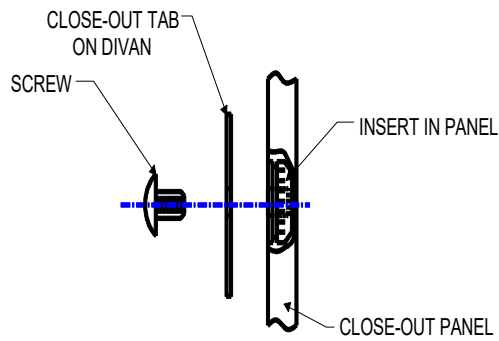

Figure 1.0B

Seat Belt & Shoulder Harness Attachment

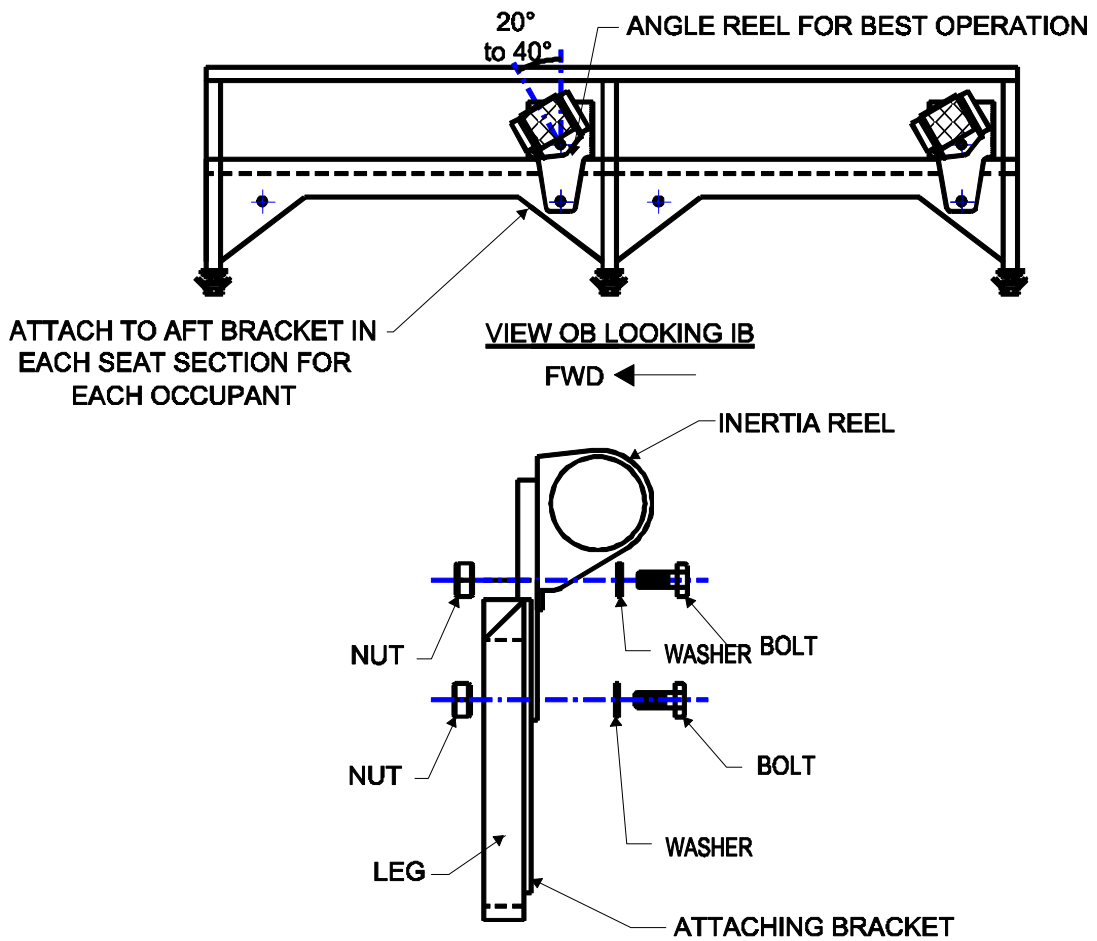

Figure 1.0C

Underseat Drawer

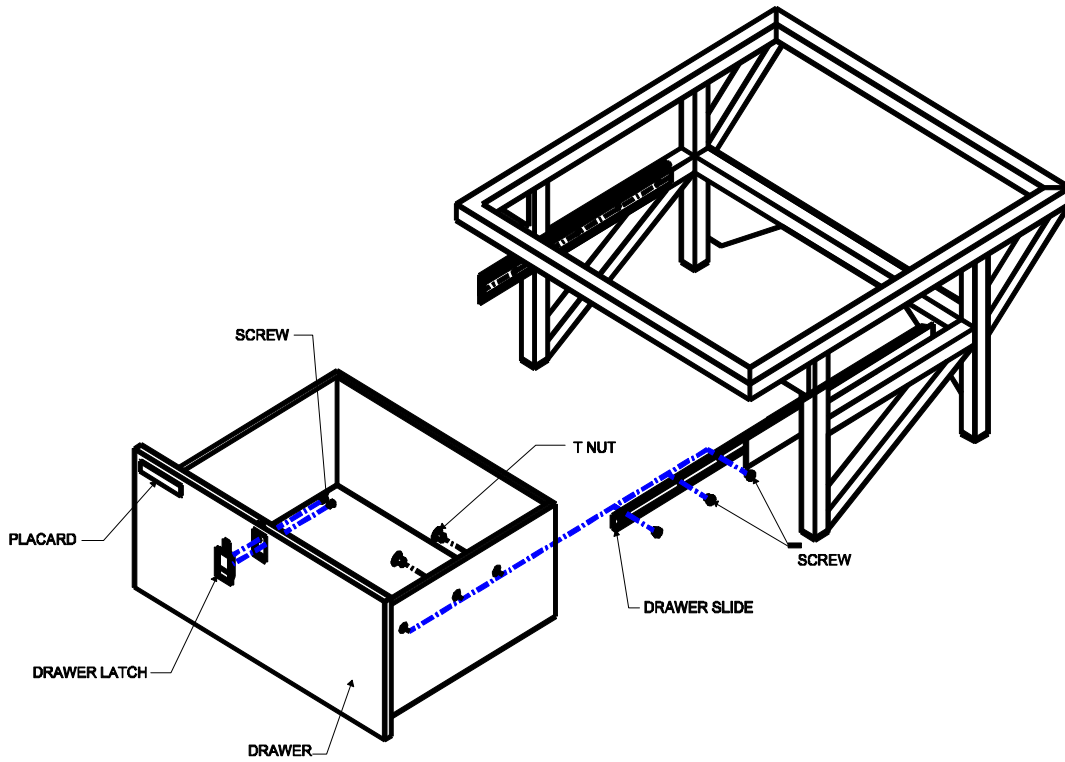
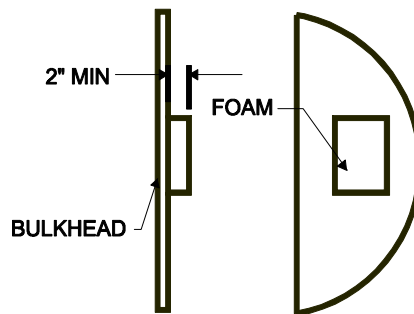
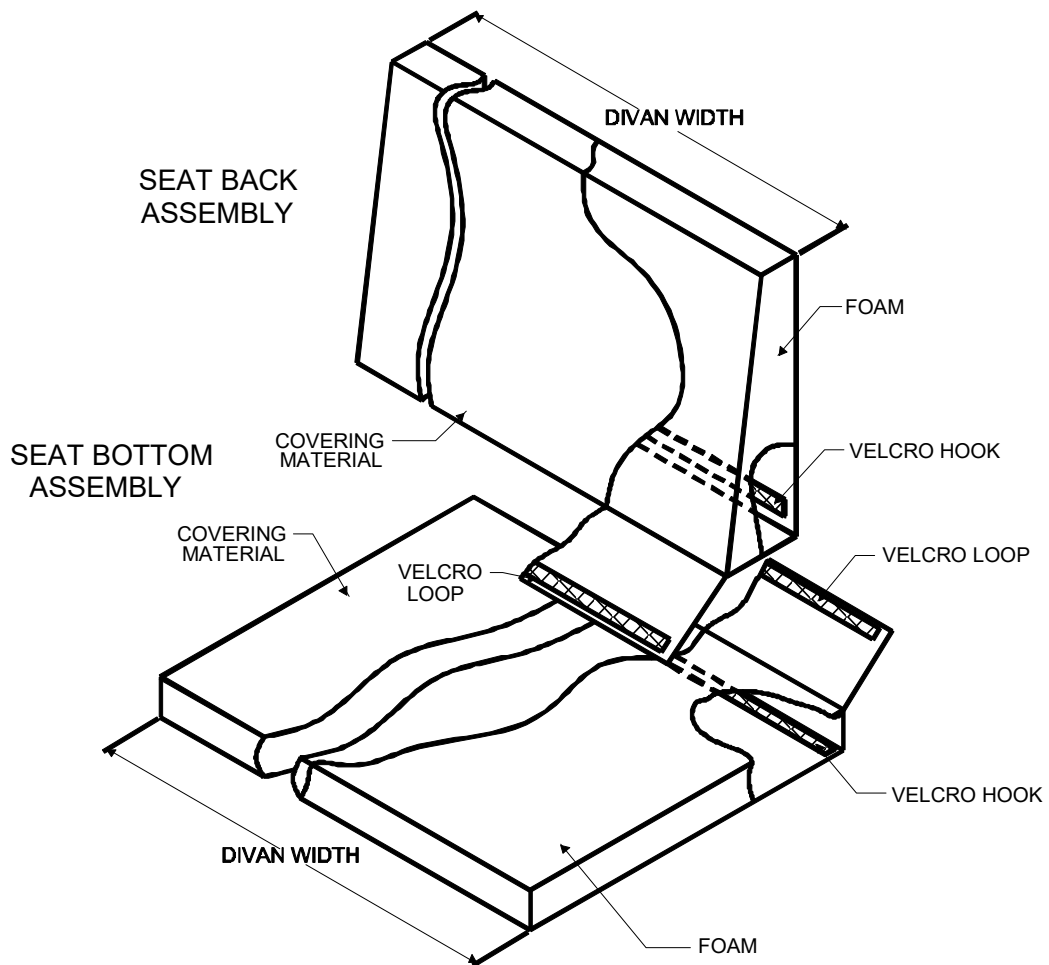

Figure 1.0D



FWD BULKHEAD

Figure 1.0E



CUSHION ASSEMBLY REFERENCE

Figure 1.0F

Armrest Box Assembly

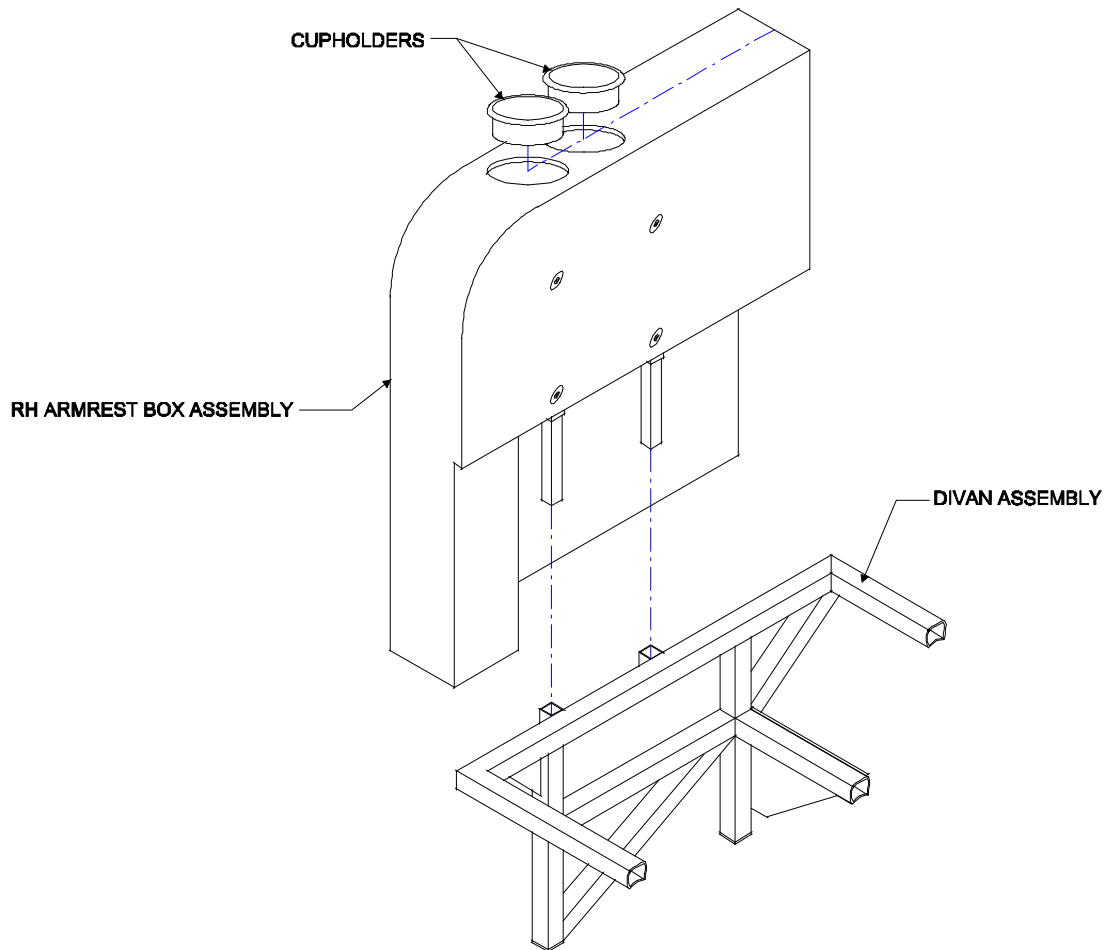

Figure 1.0G

2.0 INSPECTION REQUIREMENTS AND OVERHAUL SCHEDULE

1. To comply with 14 CFR 25.1529, continue the new divan and restraint system on the same inspection and maintenance schedule used per the Gulfstream Maintenance Manual for seats and divans.
 - a. The new divan requires no service other than inspection at normal inspection interval of 300 hours or every 12 months.
 - b. The safety belts require no service other than inspection at normal inspection interval of 300 hours or every 12 months.
 - c. Perform a detailed visual inspection of the divan bottom and back cushions and the covering of the divan assembly to detect apparent or obvious defects or irregularities.

On the cushion assemblies, check for cracks and punctures within a 4" diameter circle. The cushion assembly can have no more than three defects found within the 4" diameter circle. If a cushion develops a "lump", check to see if there are no more than two lumps within a 4" diameter circle. Any damage to the cushions outside of the described limits will require them to be replaced.

Visually inspect the covering assemblies for holes, punctures, and tears. If the damage to the covering is holes smaller than 1/2" in diameter or a cut at a maximum of 2" in length then the covering is satisfactory. The sewing of the cover assemblies cannot have a tear or cut exceeding 1" in length. Any damage to the covering assemblies outside of the described limits will require them to be replaced.

- d. Visually inspect the divan and seat assembly tubing and diaphragm for cracks and deformation. Damaged conditions can be detected as a crack at the edge of the tube or along the length of the tubes or as a crack, tear or cut found on the seat bottom diaphragm. Visually inspect all hardware for excessive wear before and after installation.

Replace the bottom diaphragm if two cracks or deformations are found within a 4" diameter circle. If a tear or cut is found with a maximum 6" length, replace the diaphragm.

There shall be no broken tubes. There shall be no sharp corners, edges, or protrusions that may injure passengers. Replace the tubes if they are bent in such a way that they are more than 2” off center. Replace the seat tubes if crack length is found to be .125” or greater. Replace the tube if a dent is found running longer than 3”. Replace the seat tubes if deformation is greater than .25” the overall thickness of the tube diameter.

Cracked or broken fasteners or fittings are to be replaced with new immediately.

For repair or replacement of damaged or broken parts or assemblies contact Aviation Fabricators Inc.

2. Inspection Time Limit for 2 Place Side Facing Divan Assembly Installations:

300 hour or every 12 months inspection for the divan assembly and safety belts

Task Code			Schedule	Date	Mech	Insp
AFI-100	a.	Conduct a General Visual Inspection (GVI) for damage to upholstery.				
AFI-101	b.	Conduct a GVI of the restraints for wear, cuts, fraying, damage, and deterioration.				
AFI-102	c.	Conduct a GVI of the restraint attachment fittings for wear and damage				
AFI-103	d.	Conduct a GVI of the divan hold down fittings for damage, security, and function.				
AFI-104	e.	Conduct a GVI of the seat frame for damage, and corrosion.				
AFI-105	f.	Conduct a GVI on the overall seat for fit and function.				

A. The new divan and restraint system are on the same inspection and maintenance schedule used per the Gulfstream Maintenance Schedule for passenger seats.

3.0 DIMENSION AND ACCESS:

The installation of the 1 or 2 place divan assemblies does not change the dimensions of the aircraft or alter the access to any existing aircraft system.

4.0 LIFTING AND SHORING

No change.

5.0 LEVELING AND WEIGHING

Due to variable divan options and weights it is the responsibility of the installer to determine the exact final divan weight and location when installing and removing the divan. For reference, the typical divan frame assembly and sub part weights are listed as follows:

1 Place Divan	= 16.0 lbs
2 Place Divan	= 28.5 lbs
Seat Belt and Hardware	= 3.0 lbs per seat place
Plug in Armrest	= 2 lbs each
Armrest Box Assembly (Without plug in armrest)	= 4 lbs each
Drawer Assembly	= 7 lbs each
Close-out Panel	1 plc = 4.0 lbs 2 plc = 7.0 lbs
Maximum Allowable Seat Weight w/ Seat Bottom Cushion and Underseat Storage	1 plc = 72 lbs 2 plc = 137 lbs

6.0 TOWING AND TAXIING

No change.

7.0 PARKING AND MOORING

No change

8.0 PLACARDS AND MARKINGS

Up to 3 placards are required in conjunction with this modification:

1. If optional drawers are installed, placard part number 15-0025 must be installed at the top of the face of the drawer where visible when open or closed.

MAXIMUM WEIGHT OF 20 LBS
DRAWER MUST BE STOWED
DURING TAKE-OFF AND LANDING

Figure 8.0A

2. If optional close out panels are installed, placard part number 17-0696-11 must be installed on the top outside of the close-out panel door so that it is visible when the door is closed.

MAX WEIGHT
15 LBS.

Figure 8.0B

3. A placard stating “to install harness over seat occupant’s fwd shoulder” is sewn on to restraint system part numbers 3091-3-181-2396 and should be legible and easily viewed by the seat occupant.



Figure 8.0C

9.0 SERVICE INFORMATION

Typical Divan Service Instructions:

A. Upholstery Cleaning:

Divan Service Instructions

1. Remove seat back and seat bottom cushion assemblies from sidewall and divan top.
2. If possible dry clean fabric cushions.
3. If dry cleaning is not possible clean fabric with Armour All fabric cleaner or equivalent.
4. Clean leather with Armour All leather cleaner or equivalent.
5. Clean drawer and/or close-out panel finish using Armour All multi-purpose cleaner or equivalent.
6. Clean and inspect restraint system for damage, fraying, cuts or seam deterioration.
7. Inspect all attachment fittings and replace if necessary.
8. Inspect overall seat for fit and function.

B. Typical Divan Maintenance Instructions:

1. Divan Assembly

The divans are self contained complete assemblies that mount to the existing aircraft cabin seat track using standard fittings in accordance with approved floor plans. Refer to Figures 1.0A.

a. Divan Installation:

The installation of the divan requires (1) setting the divan into the correct location and, (2) sliding the divan forward or aft on the track to allow the hold down fitting keeper to lock in place.

b. Divan Removal:

Removal of the divan assembly requires (1) loosening the attaching hold down fitting, (2) sliding the divan forward or aft to remove the hold down fitting from locking into the seat track, and (3) lifting the divan from its previous location.

2. Cushions

Seat back and seat bottom cushion assemblies are removed by simply pulling the cushion inboard away from the Velcro on the sidewall or up away from the Velcro on the pan of the divan assembly, respectively. All covering and upholstery materials must comply with 14 CFR 25.853 as stated on the installation instructions D-10739. Refer to Figure 1.0F for Cushion Assembly Reference.

3. Closeout Panels

Underseat close-out panel removal is accomplished by removing screws from under the divan that are attached to inserts in back of panel and attached through tabs on divan frame. Ref. Figure 1.0B

4. Restraint System

- a. Seat belt removal is accomplished by unhooking the belt from the tie down fitting hardware or by removing the tie down fitting from the existing aircraft seat track.
- b. The shoulder harness is removed by loosening the nut and bolt from the divan attachment bracket. Ref. to Figure 1.0C

5. Drawers

Underseat drawers are removed from the divan by removing slide screws attached to the drawer sides. The drawer slides are removed from the divan by removing attaching screws. Figure 1.0D

6. Forward Bulkhead Pad

Per the installation instructions D-10739, of the divan assembly, if the divan is installed next to a forward bulkhead, the bulkhead must be properly padded to comply with 14 CFR 25.785. Figure 1.0E

7. Oxygen Dispensing Unit Availability

Per the installation instructions, D-10739, of the divan assembly, the divan installation must comply with 14 CFR 25.1441. Each dispensing unit must be capable of being readily available to be placed into position on the face of the seat occupant.

8. Armrest Box

Armrest box removal is accomplished by lifting straight up and pulling the armrest out of its supports. Ref. to Figure 1.0G

C. RECOMMENDED OVERHAUL PERIODS

No additional overhaul time limitations and requirements apply to the Aviation Fabricators 1 or 2 Place Divans.

10.0 AIRWORTHINESS LIMITATIONS

The information contained herein supplements the basic Maintenance Manuals only in those areas listed when the aircraft is modified in accordance with Aviation Fabricators STC Data List AF-242 Rev K or later approved revision. For limitations and procedures not contained in this supplement, consult the basic Airplane Maintenance Manuals.

The Airworthiness Limitations section is FAA approved and specifies maintenance required under Sec. 43.16 and 91.403 of the Federal Aviation Regulations unless an alternative program has been FAA approved.

AIRWORTHINESS LIMITATIONS - LOG OF REVISIONS			
REV.	EFFECTED PAGE (s)	DESCRIPTION of REVISION	DATE
(IR)	All	Initial Release	01/03/14

AIRWORTHINESS LIMITATIONS

There are no Airworthiness Limitations to the aircraft with the addition of the divan installed by this STC.

Distribution:

Per the requirement of Appendix H of 14 CFR Part 25 paragraph H25.1 (c), the changes made to the ICA by the applicant will be distributed via mail by means of paper copy.